



From: Forklift Training Systems

RE: Overhead crane light information and pricing

Product Background:

This unique product alerts pedestrians and vehicles of nearby overhead crane use.

Specifications:

- Power: 140 Watts
- Voltage: 9-32 VDC, can run on up to 277 VAC with optional power converter. (A 480 VAC converter is also available by special order)
- Lumens: 10,000 lumens (each light creates one spot or one line)
- LEDs: 14 x 10 watt (Cree LED)
- LED color: Red or blue
- Beam Type: Spot or line beam
- Working life: Up to 50,000 hours
- Size: 7.7" X 3.1" X 8.7" (195 X 78 X 221mm)
- Weight: 7 pounds
- Waterproof: IP67
- Working temperature: -45~85°C
- Material: Aluminum die-cast housing.
- Approval: ISO9000--CE--RoHS
- Adjustable mounting bracket: 150 degree up/down.
- Cable Length: 3 meters (9').
- Two-year warranty
- Available in red or blue colors. We suggest red, since it seems to show up better from higher heights and differentiates itself from the smaller forklift blue spot lights which are now very common.
- Functional distance depends greatly on floor and lighting conditions. When used as a spot they can potentially function up to 80' and up to 25' when used as a line. We suggest buying one to test and try first.

Features:

- Easy to install.
- 9' cable connects to 9-32 volts DC input power, installs in minutes. We can also recommend a converter that allows the use of AC power if needed on overhead cranes.
- Includes an adjustable mounting bracket, providing an easy connection to any overhead crane.
- IP67 rated for indoor and outdoor use.
- Heavy duty cast aluminum housing with stainless steel bracket.
- Optional flasher, to pulse your light(s) to make them more visible (\$30 to flash up to 4 lights together)

How it works:

- Mount the crane spotlight on any overhead crane.
- The 150 degree up/down mounting bracket allows precise positioning of beam on floor below.
- The beam is positioned so pedestrians below are aware of the crane hook that is coming.
- Can be used in a single light, double light and quad light configuration depending on your application.

Benefits:

- Reduce accidents! Many crane accidents involve pedestrians, so warning them of the presence of the hook/load is highly beneficial.
- When a pedestrian or vehicle operator sees the beam on floor, they know danger is closer by.
- Very effective for more precise positioning of the crane by the crane operator.

Pricing: Includes the mounting bracket and optional lens to create a straight line.

1-9 lights = \$350 per light

10-99 lights = \$315 per light Contact us for a quote on over 100 lights

Red light part number: TPB140R (Replaces former part # FWN-72W-MAXI-R)

Blue light part number: TPB140B (Replaces former part # FWN-120W-MAXI-B)

Prices do not include UPS ground shipping; we can ship prepaid or with your UPS account.

Optional power converters: Allows the lights to wire into 100-240 VAC (also 277 VAC in North America)

Single light converter \$135 Part# ELG-150-24A-3Y (Replaces former part # FWN-PS-CLG150-24)

Multiple light converter, powers up to 4 lights \$360 Part# HLG-600H-24A (Replaces former part # FWN-HLG-600H-48A)

You can see our [video](#) and pictures on the crane spot light in action and also order it online at [Crane spot light](#)
One light, two lights and four lights per crane configurations are common, depending on the application. You can choose to use a spot light or straight line, since the lens to produce a line is included at no additional cost.

Misc. Details:

Our goal is to ship your order within 24 hours of you placing it. We accept most major credit cards, purchase orders and checks as forms of payment. We can send you a W-9 by email if we are not currently set-up in your system. We also supply the US government and military; contact our office manager, Jessica Hoover, at 614-583-5749 for more details on those types of purchases.



Single spot light configuration (available in red or blue)



Two spot light configuration (available in red or blue or a mix)



Four spot line configuration (available in red or blue or a mix)

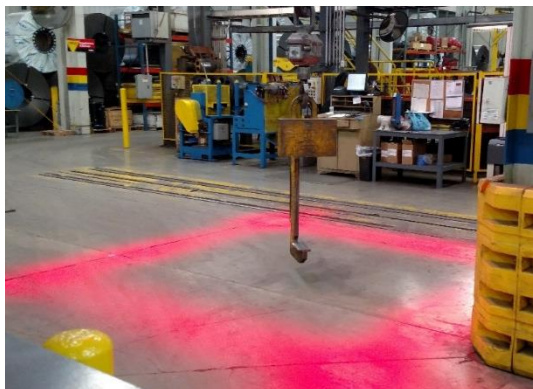

Quad line configuration (4 separate lights - available in red or blue or a mix)

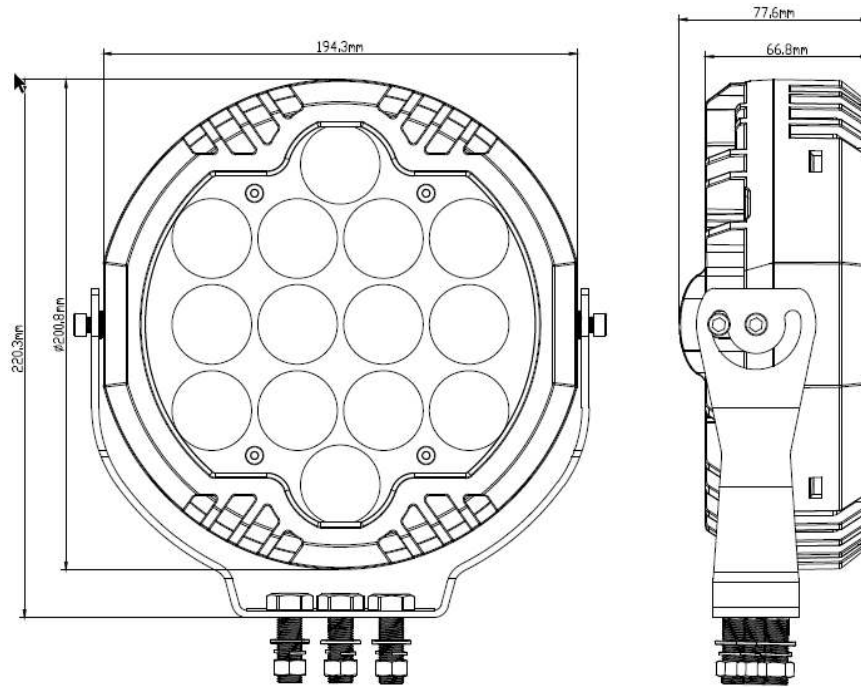

For more information or to place an order, contact Jessica Hoover of Forklift Training Systems

Tel: 614-583-5749

Fax: 443-947-2470

Email: info@forklifttrainingsystem.com